



**SHEPARD**

Volume 16 Number 4  
August/September 2011

# UNMANNED

**VEHICLES**

DEDICATED TO THE UNMANNED SYSTEMS INDUSTRY



## Capability and beyond

Future enhancements for next-generation UAS

### **NO MORE DISMOUNTS?**

UGVs for force protection

### **MODULAR MINIATURES**

The demand for SUAS

### **THE LIGHTER SIDE**

ISR aerostats in focus

[www.UVonline.com](http://www.UVonline.com)



As developers struggle to convince military customers of new applications for unmanned aircraft, **Andrew White** and **William F Owen** discover how an Israeli company is developing a twin-fan design to solve some of the current problems surrounding VTOL UAVs.

# The Air Mule cometh

The prototype Air Mule, seen during recent flight trials. (Photos: Urban Aeronautics)

Urban Aeronautics used the Paris Air Show in June to dismiss conventional rotary-wing VTOL UAVs as an 'interim solution' for cargo resupply missions. Speaking to *Unmanned Vehicles*, marketing VP Janina Frankel-Yoeli said only a rotorless VTOL UAV would satisfy this requirement, in preference to systems including Boeing's A160T Hummingbird and the Lockheed Martin/Kaman K-Max, although she conceded that these were 'better than manned helicopters' for such purposes.

Outlining plans for the Air Mule to conduct its first full working demonstration next year, she said: 'Helicopters are more limited in aerial access to the urban environment, but the Air Mule has no rotors, which are the biggest cause of helicopter crashes.' Frankel-Yoeli said the aircraft would offer a solution to USMC requirements for a cargo resupply capability in Afghanistan.

The Air Mule is one of several designs that the Urban Aeronautics has developed from the Piasecki VZ-8 AirGeep II, a little-known concept that emerged in 1961. As the name implies, the aircraft was designed to be a 'flying jeep'. Powered by two 2.5m diameter ducted vertical fans mounted fore and aft, it exhibited poor flight characteristics, according to industry sources. The US Army

project was subsequently cancelled and all but forgotten.

However, a small team of engineers and aerodynamicists in Israel began to research a twin-fan design to create a VTOL UAV that could operate within urban terrain and close to obstacles, with a much-needed degree of immunity to rotor blade strikes. A circuitous development route led to the Air Mule – a 640kg UAV capable of carrying 560kg of fuel or payload.

## THE BIG DIFFERENCE

What makes the Air Mule so different from the AirGeep II are the technological advances that have been made since the 1960s in terms of controls and power packs, as well as in understanding VTOL aerodynamics.

'The Air Mule uses the same fore and aft ducted fans, but these now have computer-controlled inlet and outlet vanes, which give the vehicle probably the most precise control response of anything flying today,' explained Rafi Yoeli, founder and CEO of Urban Aeronautics. 'Using the vane control system, the vehicle can move in all six degrees of freedom independently.'

'The aircraft also has additional intake louvres in the front and rear of the fore and aft fans, respectively. These substantially

increase fan efficiency with the louvres closed in the hover, but at the same time facilitate high-speed flight by opening up gradually as the vehicle picks up forward speed, resulting in a smooth ingress of airflow and a reduction in the drag of the duct walls.'

An all-composite airframe, married to a 730shp Turbomeca Arriel 1 helicopter engine, delivers a substantially improved power-to-weight ratio. Production aircraft, however, will almost certainly have an Arriel 2 with full authority digital engine control. In forward flight, the centre-section 'hump' of the vehicle delivers an estimated 20% increase in lift, allowing an extra 300kg of payload when using a rolling take-off. Meanwhile, two small tail-mounted thrust fans aid propulsion.

The cargo is carried in two equally sized compartments on either side of the upper centre section. The aircraft will operate at a 12,000ft pressure altitude, which makes it suitable for the vast majority of operations worldwide.

## PAYLOAD POTENTIAL

Potentially, a production Air Mule II will be able to deliver a 125kg payload to anywhere it can land within a 300km radius, and fly the same payload back with a dash speed of 100kts or 90kts in cruise.



The outlet vanes, propellers and inlet vanes of the rear fan.

Helicopters are vulnerable to small arms fire and MANPADS, and are increasingly expensive to operate, to the point where they are becoming inefficient for certain tasks. This is particularly evident when it comes to transporting payloads in the sub-500kg category. It is simply not efficient to employ a CH-47 or UH-60 for small payloads over short ranges, especially in terms of available crew flying hours.

Air Mules can work in low-visibility conditions that would normally ground manned aircraft, and they can fly around the clock, pausing only for fuel, loading and maintenance. Moreover, the loss of manned helicopters to enemy action can have a significant political impact.

This is not to suggest that this kind of UAV would replace support helicopters completely. It would, however, enable their crews and flying hours to be more effectively allocated.

#### COMPETITIVE ADVANTAGE

Other battlefield VTOL UAS options include Boeing's unmanned AH-6 Little Bird and

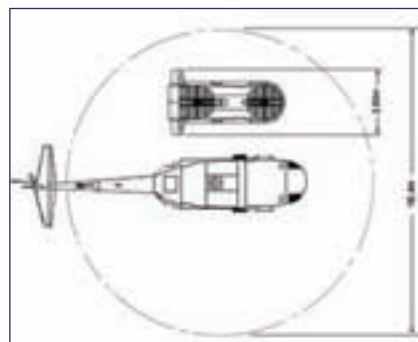

Air Mule vs UH-60: an illustration of the relative rotor disc clearances required.

According to performance estimates based on initial testing, the same applies to a 500kg payload delivered to within 100km of the aircraft's starting point. In theory, this could mean delivering half a tonne of ammunition to the front line and, if necessary, recovering two casualties on the return journey.

With some armies still struggling to fully understand UAV applications, the main question that militaries must address here is whether they want casualties and soldiers to be flown in the current operating environment by unmanned systems. The Air Mule II will be equipped with a zero-zero ballistic parachute, and is intended to be certified in line with US FAR Part 27 regulations, in order to be safe for passenger transport.

From a battlefield medicine point of view, the concept means that casualties would need to be stabilised to the degree that they can be left unattended for at least 35 minutes, given a flight distance of 100km. It therefore seems more feasible to move the casualty to a location from which they can be safely extracted by conventional helicopter. However, this is undermined by the advantages of the Air Mule compared to in-service manned platforms.

Schiebel's Camcopter S-100, but Yoeli argued: 'An Air Mule can fly to any receiving party, landing in almost any terrain, and have them unload its cargo in near total darkness or thick fog, with the blades turning and engine running without presenting any hazard to the men on the ground. The Air Mule also has far better sloping ground performance than a helicopter, with none of the terrain proximity hazard of a main or tail rotor.'

The ducted fans also have a far greater tolerance of damage and foreign object ingestion than conventional rotor blades. This means an Air Mule can land in a wide range of places, such as narrow streets and woodland clearings, that a UH-60 cannot.

'If needed, an Air Mule has the ability to operate from extremely small vessels, relative to the size and weight of the aircraft,' Yoeli continued. 'For example, it could operate from a 60t deck-equipped *Dvora II*-class patrol boat. While a Camcopter S-100 could do the same, this platform only has a cargo payload of 53kg, compared to the 500+ of the Air Mule, which in theory could also carry two Sea Skua-type missiles.'

As regards transport for deployment, two partly assembled Air Mules can be carried in a C-130, minus the thruster fans, which would have to be re-attached prior to flight. Without these, the Air Mule is narrow enough to fit inside a 40ft ISO container. This gives the vehicle the fairly obvious capability of operating from the back of any flatbed truck that can carry a 20ft ISO container.

This may all seem like another hypothetical UAV concept that is merely 'interesting.' However, in January 2011, the Israeli MoD disclosed that it is participating in the funding of an Air Mule technology demonstration, with a casualty evacuation system being cited as the major capability needed. Flight demonstrations are expected to be completed during 2012, according to Yoeli, who added: 'We will probably demonstrate practical UAV medical evacuation within the next five years.' He also told *UV* that a number of NATO militaries have expressed a strong interest in the project. **uv**